

**STRAIGHT PLUG CLAMP TYPE
CABLE 1/2" HELICAL**

R161.037.036

SERIES

N

Hex. 0.812 / flats
(Hex. 20.62 / plats)

0.687 / 2 flats
(17.45 / 2 plats)

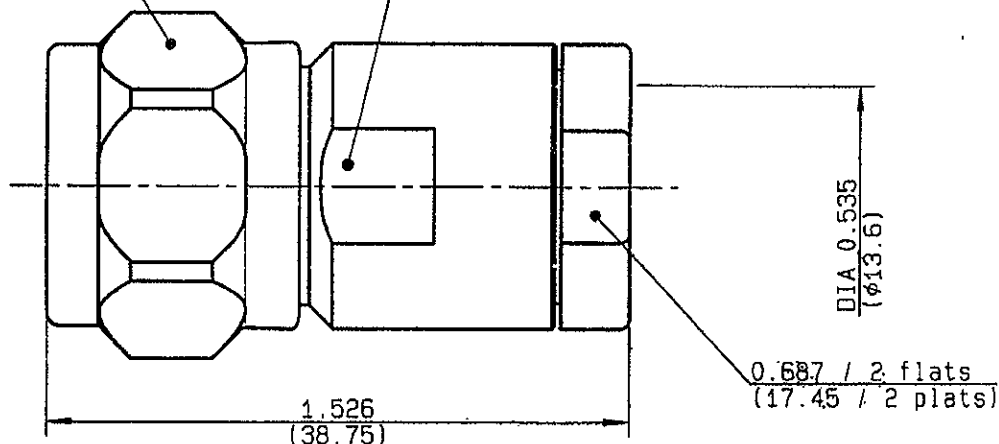

NOMINAL IMPEDANCE	50	Ω
FREQUENCY RANGE	0-11	GHz
TEMPERATURE RATING	-55/+155	$^{\circ}\text{C}$
V.S.W.R	TBD +	$\times F(\text{GHz})\text{Maxi}$
RF INSERTION LOSS	0.048	$\sqrt{F}(\text{GHz}) \text{ dB Maxi}$
VOLTAGE RATING	1400	$V_{\text{eff}} \text{ Maxi}$
DIELECTRIC WITHSTANDING VOLTAGE	2500	$V_{\text{eff}} \text{ Mini}$
INSULATION RESISTANCE	5000	$M.\Omega \text{ Mini}$
HERMETIC SEAL	NA	$\text{Atm. cm}^3/\text{s}$
LEAKAGE (pressurized only)	NA	
MECHANICAL DURABILITY	500	Cycles
WEIGHT		gr
SPECIFICATION		

CABLES 3.7/50 CCE3-1/2"
FSJ4-50B - 1/2"
FSJ4-50B-4 - 1/2"
FSJ4RN-50B
HCF 1/2" Cu2Y

OTHERS CHARACTERISTICS

CABLE RETENTION	500	N Mini
CENTER CONTACT RETENTION		
Axial force - mating end	NA	N Mini
Axial force - opposite end	68	N Mini
Torque	NA	cm.N Mini
RECOMMENDED TORQUES		
Mating	NA	cm.N
Panel nut	NA	cm.N
Clamp nut	800	cm.N

CONNECTOR PARTS

MATERIALS

FINISH

(all values are given in micrometers)

BODY	BRASS	SILVER 5 PASSIVATED OVER COPPER 0.5
OUTER CONTACT	BRASS	SILVER 5 OVER COPPER 0.5
CENTER CONTACT	BRASS	GOLD 1.3 OVER COPPER 0.5
INSULATOR	PTFE	-
GASKET		-
OTHERS PIECES		SILVER 5 PASSIVATED OVER COPPER 0.5

RAFFAEI

ISSUE
9903C00

CREATION DATE
22-AUG-97

FILE PART-NUMBER
95-0400-555



RADIALL®

The information given here is subject to change without notice. Design changes may be in order to improve the product.

Connect to the future



R161.037.036

ISSUE 9903C00 SERIES N

CLAMP NUT

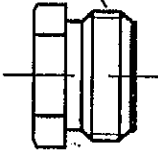

CENTER CONTACT

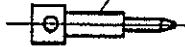

BODY



①

Strip the cable.

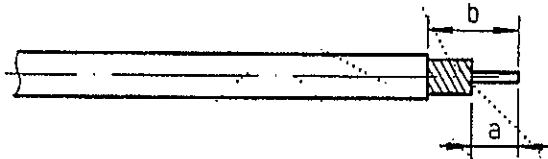

Stripping	a	b	c	d	e
inch	0.138	0.591	0	0	0
mm	3.5	15			

②

Screw clamp nut onto cable shield leaving 0.122(3.1) of cable helix thread extending past the end of clamp nut. Secure clamp nut and screw body onto clamp nut until cable extending past clamp nut is fully compressed. Unscrew body from clamp nut. Screw clamp nut away from end of cable to allow for room when soldering center contact to cable.

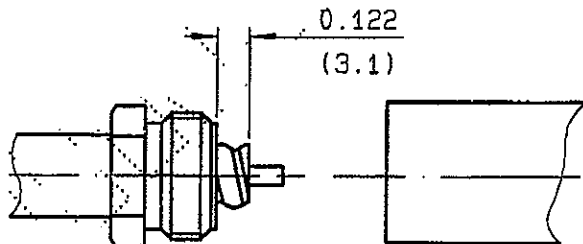

③

Trim dielectric back even with or slightly below end of cable shield. Trim center conductor of cable to 0.225 (5.7). Solder center contact onto cable center conductor the distance shown from the compressed cable shield end. Using solder gage A731.15.020

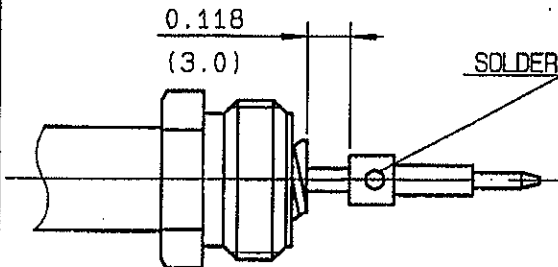

④

Screw clamp nut to end of cable shield. Screw sub-assembly into body.